

# KANOU LEMARI LACI 3 PINTU

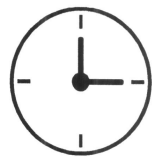

**60 Menit**



**2 Orang**

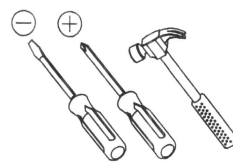

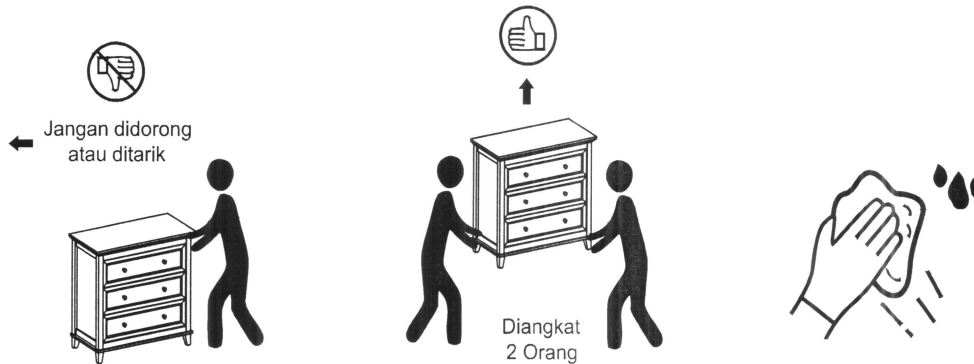

1. Beban pada ilustrasi di bagian **INFORMASI PRODUK** adalah beban dalam keadaan diam dengan distribusi merata pada semua permukaan.
2. Pindahkan produk ini dengan cara mengangkat, jangan didorong karena dapat merusak bagian kaki.
3. Bila terkena cairan, langsung bersihkan dengan menggunakan kain yang lembut.
4. Jangan meletakkan benda-benda bersuhu tinggi tanpa menggunakan alas.
5. Permukaan produk tidak boleh terkena cairan kimia. contoh : thinner, cat kuku.
6. Membersihkan produk cukup dengan kain kering, namun bila diperlukan dapat menggunakan kain lembab bukan basah.
7. Pelengkap pengaman wajib digunakan untuk mencegah furnitur terjatuh. Pelengkap pengaman sudah termasuk di dalam paket furnitur ini dan cara instalasi tercantum.
8. Jangan memanjat atau bergelantungan di laci, pintu atau rak.
9. Letakkan benda berat di laci paling bawah.
10. Laminasi permukaan menggunakan material dasar Kertas.
11. Jangan meletakkan benda panas langsung diatas permukaan. Selalu gunakan tatakan penahan panas. Terdapat resiko permukaan bergelembung akibat kontak fisik dengan benda panas akibat penguapan lapisan adesif antara papan kayu dengan lapisan laminasi.
12. Jangan meletakkan benda basah langsung diatas permukaan. Selalu gunakan tatakan agar permukaan tidak terkena cairan.  
Terdapat resiko permukaan berubah warna dan lapisan menjadi lapuk akibat kontak fisik dengan benda basah.

## PART LIST

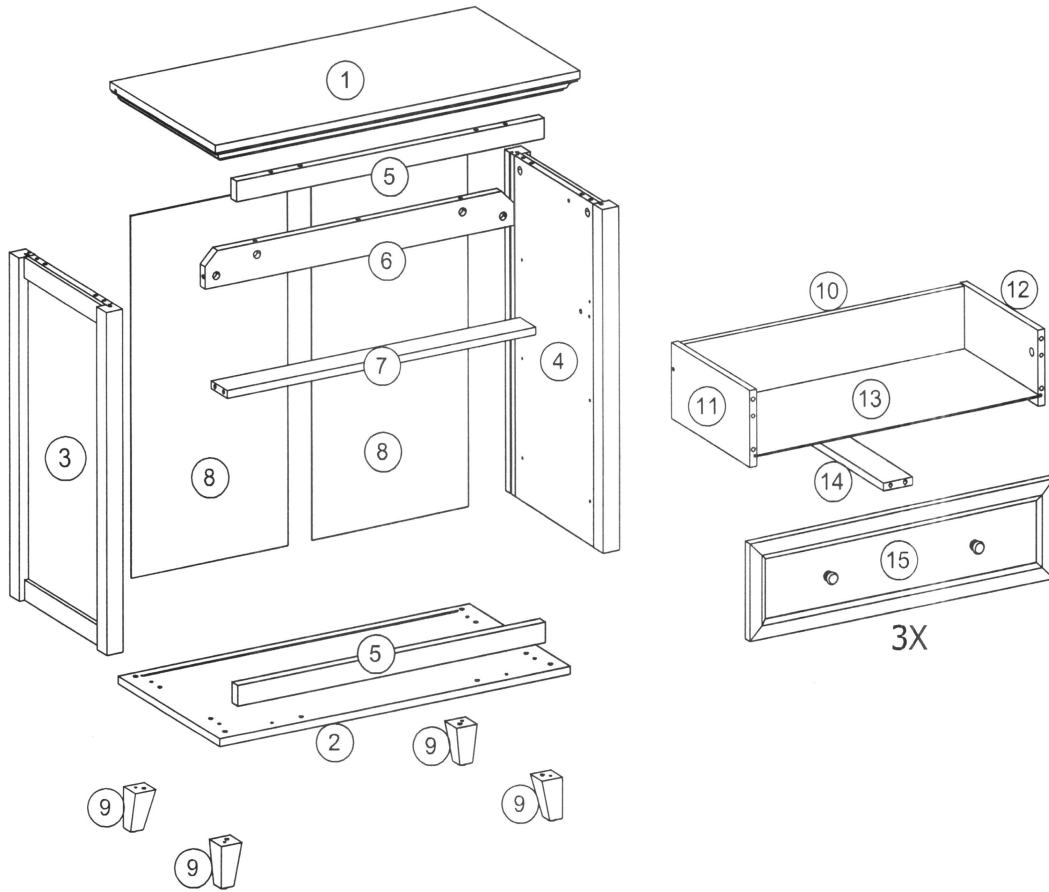

No.	Size	Qty
1	796 x 398 x 40 mm	1
2	765 x 383 x 15 mm	1
3	656 x 370 x 36 mm	1
4	656 x 370 x 36 mm	1
5	672 x 40 x 21 mm	2
6	673 x 70 x 18 mm	1
7	673 x 60 x 15 mm	1
8	692 x 341 x 2.5 mm	2

No.	Size	Qty
9	80 x 50 x 50 mm	4
10	617 x 144 x 15 mm	3
11	296 x 146 x 15 mm	3
12	296 x 146 x 15 mm	3
13	292.5 x 628 x 2.5 mm	3
14	280 x 64 x 15 mm	3
15	666 x 188 x 18 mm	3

# HARDWARE LIST

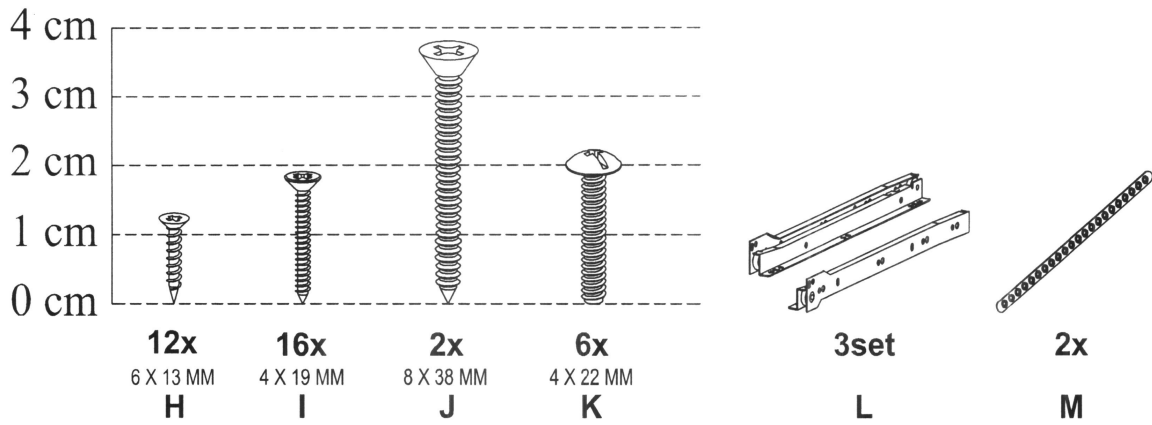
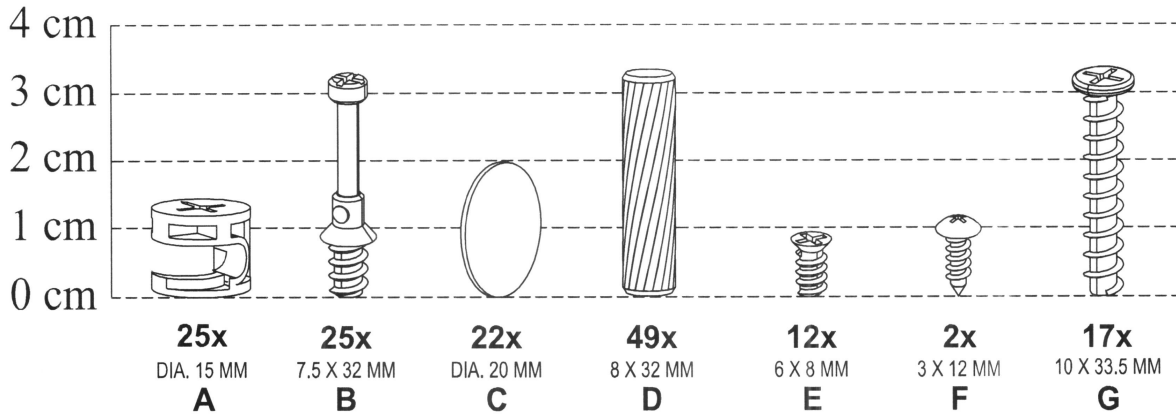

**6x**  
**N**

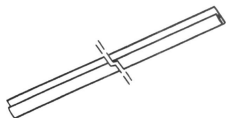

**1x**  
**O**



**2x**  
**P**

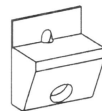

**16x**  
**Q**



1

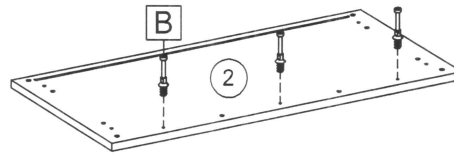
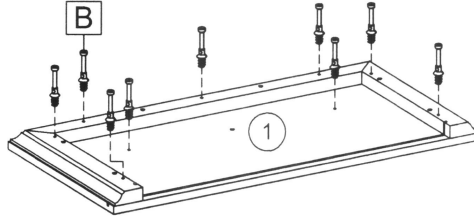
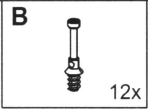

2

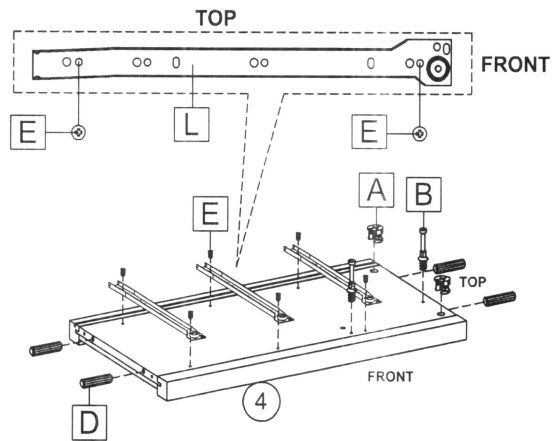
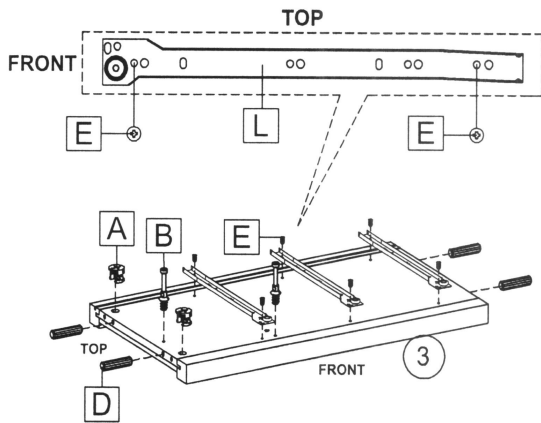
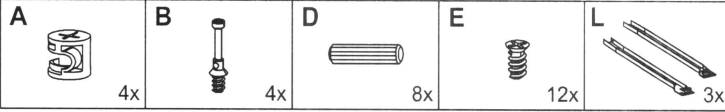

3

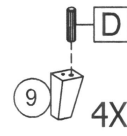
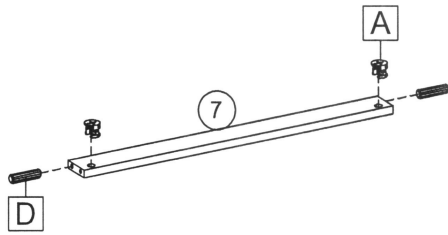
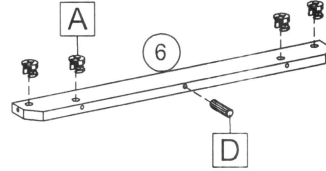
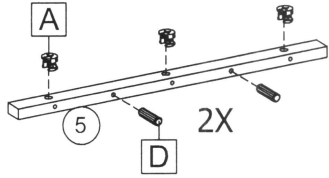
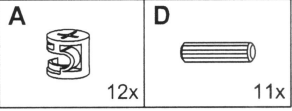

4

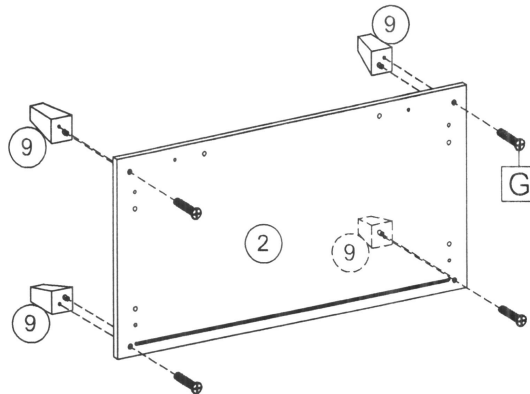
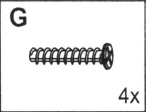

5

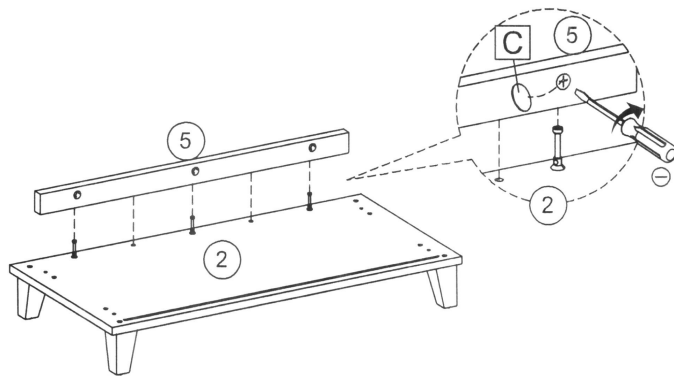

6

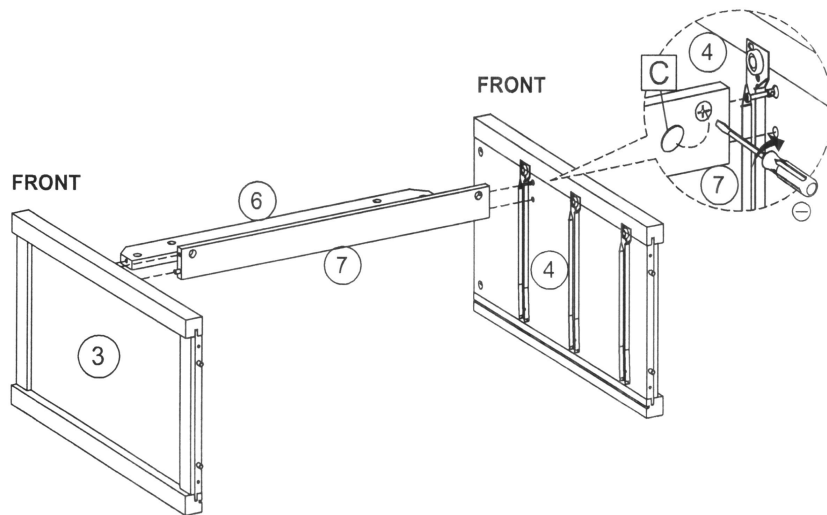

7

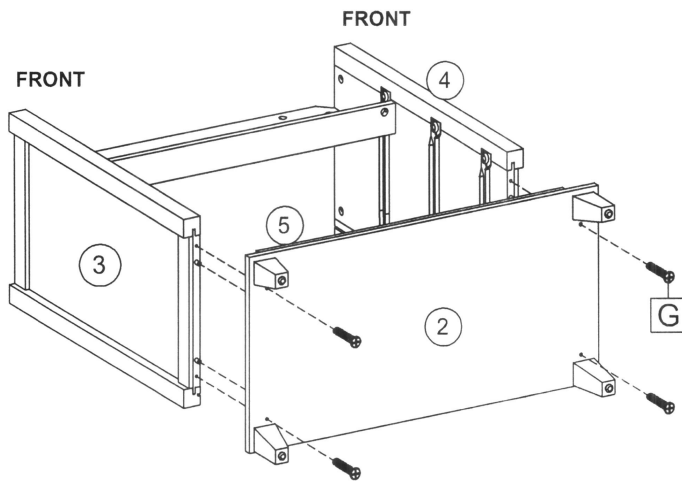
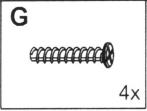

8

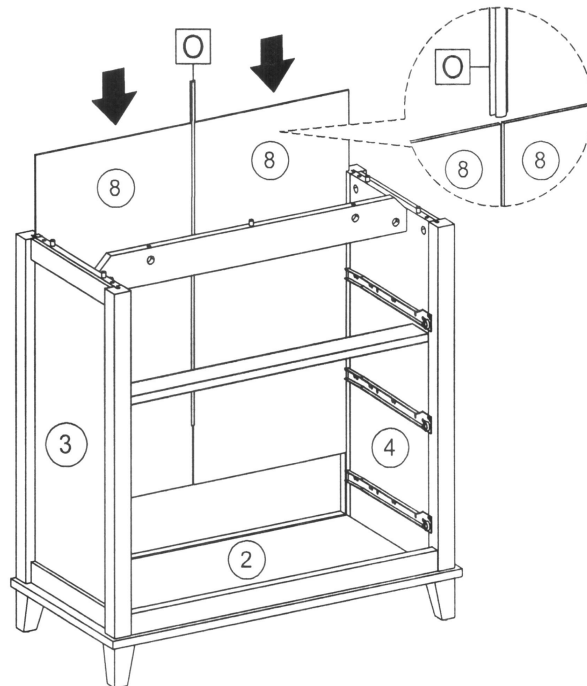
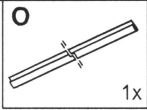



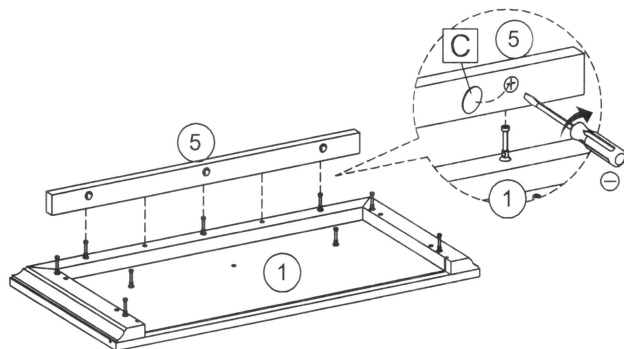
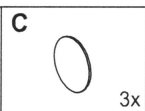

9

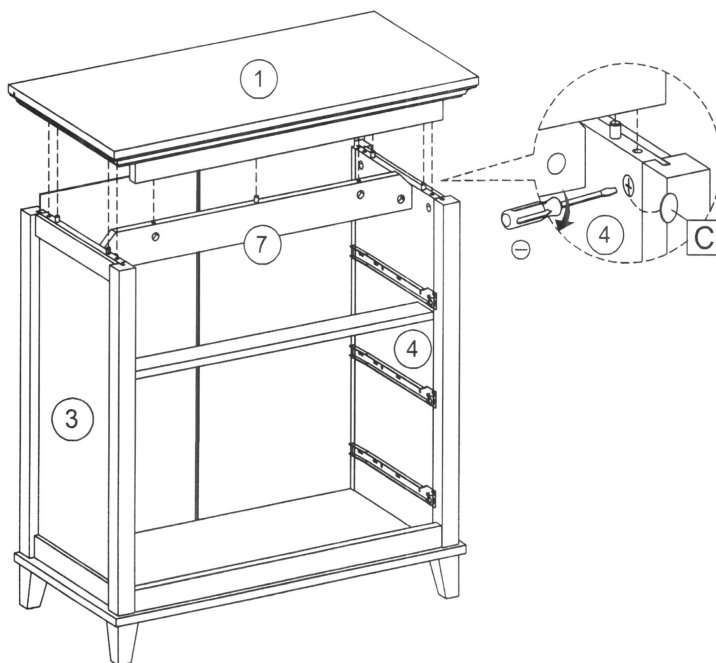
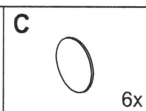

10





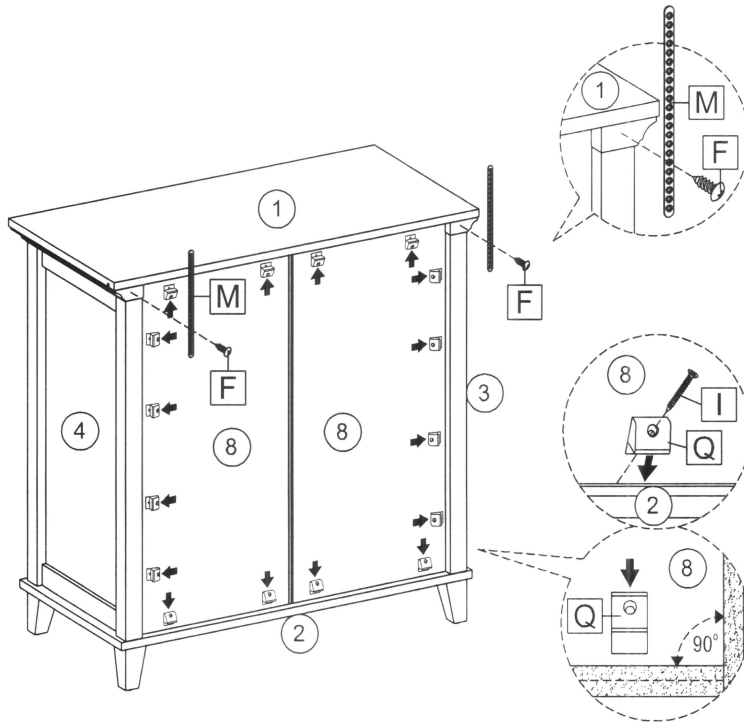

# 11

<b>F</b>  2x	<b>I</b>  16x	<b>M</b>  2x	<b>Q</b>  16x
---	--	---	--



# 12

<b>A</b>  9x	<b>B</b>  9x	<b>D</b>  30x	<b>K</b>  6x	<b>N</b>  6x
---	---	--	---	---

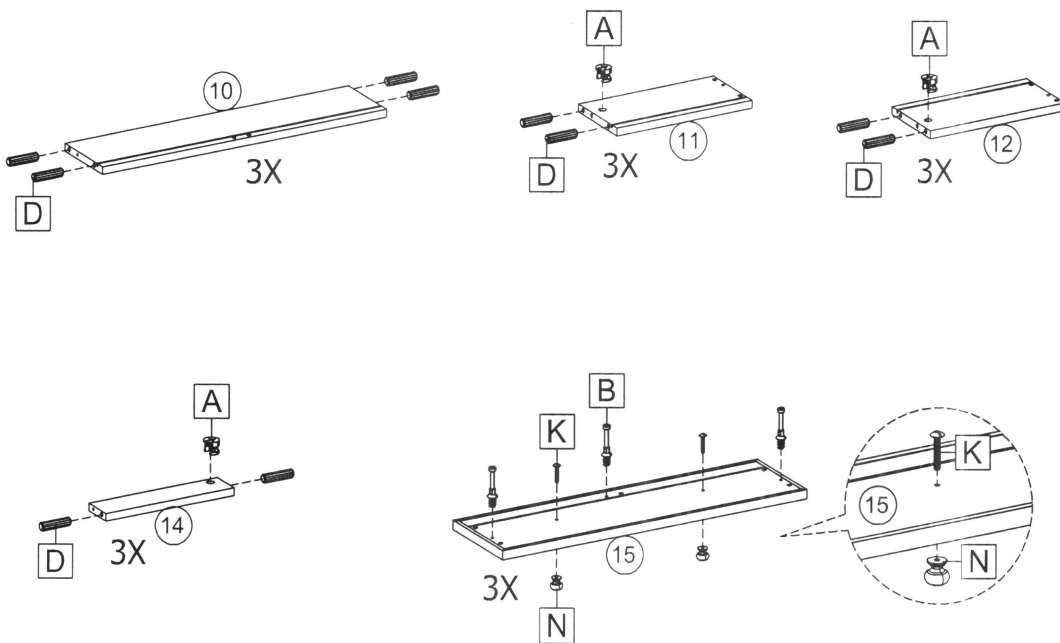

13

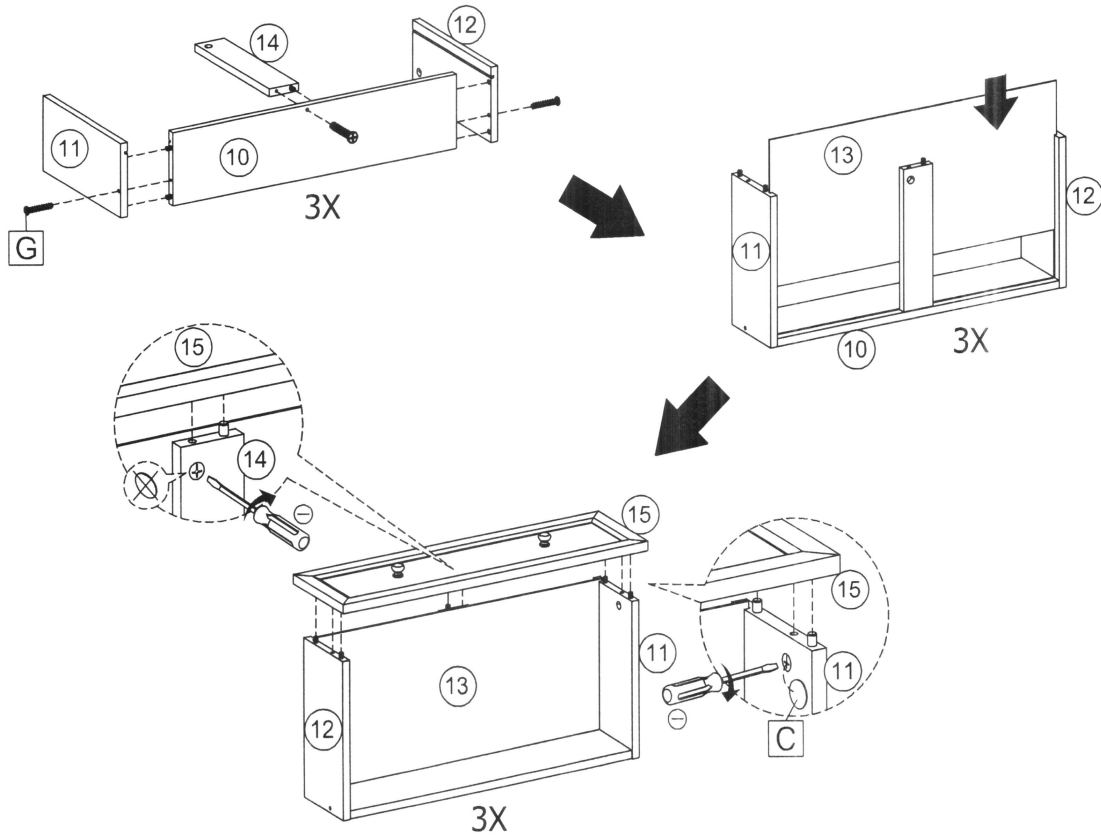
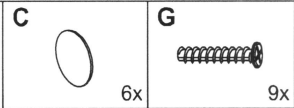

14

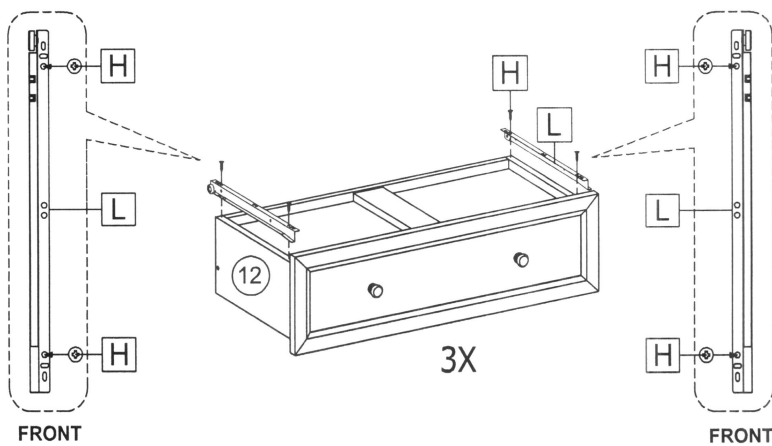
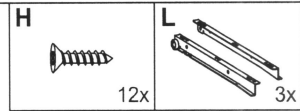

15

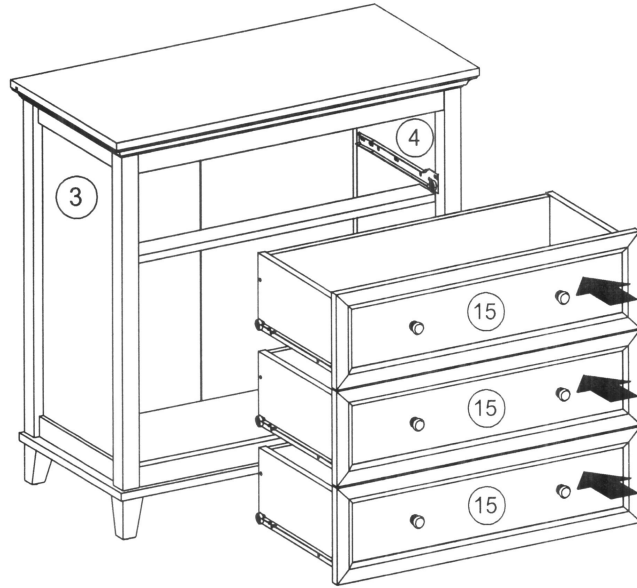

16

